

	1	2	3	4	5	6	7	8	
A	9pin	10pin	11pin	12pin	13pin	14pin	15pin	16pin	17pin

Recommended Panel Cut-out

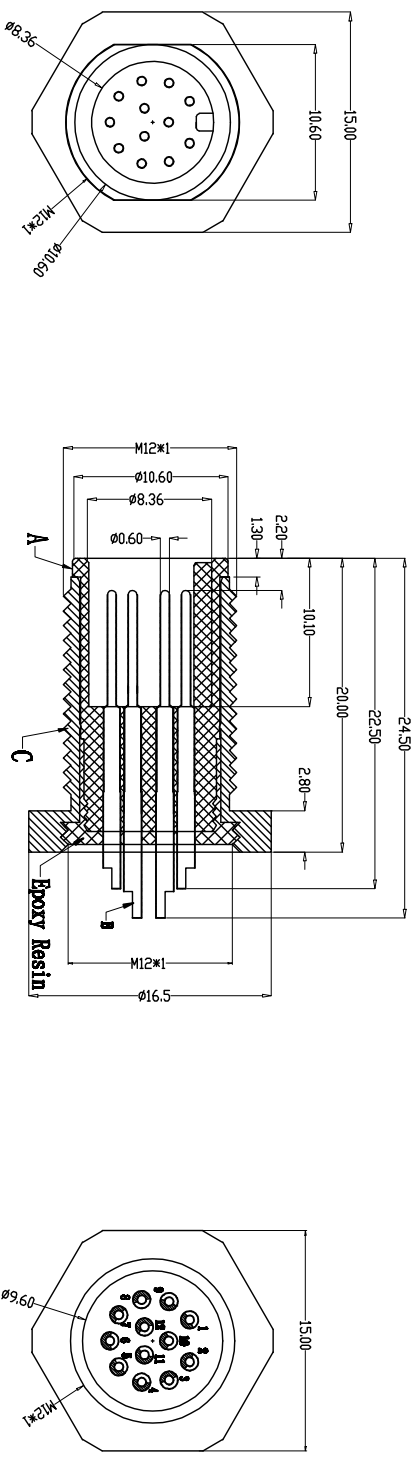
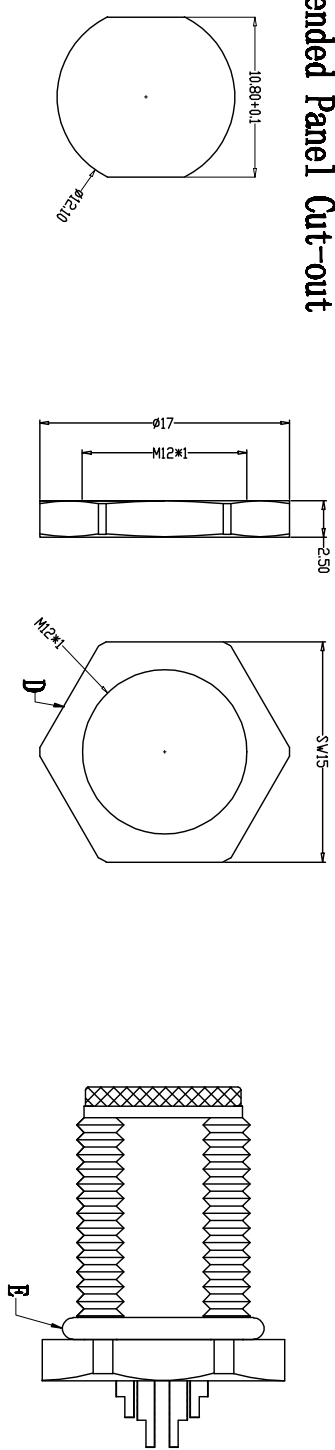

由 Autodesk 教育版产品制作

由 Autodesk 教育版产品制作

PARTS	MATERIALS	TREATMENT	AMOUNT
A HOUSING	PAGE6+GF	GOLD PLATED	1
B CONTACT	BRASS		9~17
C OUTER CONTACT	BRASS	NICKEL PLATED	1
D NUT	BRASS	NICKEL PLATED	1
E O-RING	EPDM	BLACK	1
F			

Engagement force	≤50N	Rated voltage	30V
Disengagement force	≥10N	Rated current	1.5A
Mechanical lifespan	≥500	Insulation resistance	≥1000MΩ
IP rating	IP67/IP68	Contact resistance	≤10mΩ
Flammability	UL94 V-0	Operation Temperature	-40° C~105° C

Dongguan Changjun Electronics Co., LTD		TITLE:	
东莞市昌骏电子有限公司		M12防水型连接器公头 前视图式M12 5W1ST	
TOLERANCE		PART NO.:	
±0.05		0-connector-17-pin-5w1st	
±0.10		DRAWING NO.:	
±0.20		CP-M120135	
±0.50		SCALE:	
ANGLE		1 : 1	
DRAWN:		CHECK:	
Xie Wenjun		Long Jichang	
DATE:		2022-01-05	