

A	1				2				3							
	pin位	2pin	3pin	4pin	5pin	6pin	7pin	8pin	pin位	2pin	3pin	4pin	5pin	6pin	7pin	8pin
X 值	1.00	1.00	1.00	1.00	1.00	0.80	0.80	0.80	0.80	0.80	0.80	0.80	0.80	0.80	0.80	0.80
A-ONE 图形																
B-ONE 图形																
D-ONE 图形																

Recommended Panel Cut-out

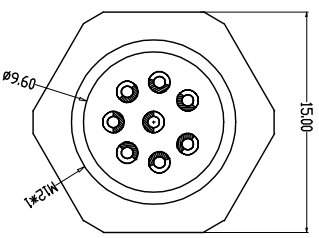
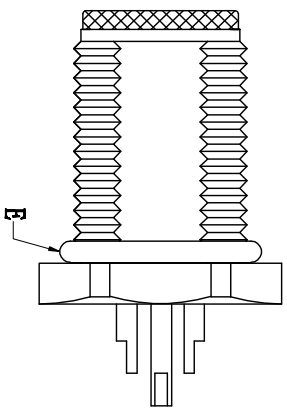
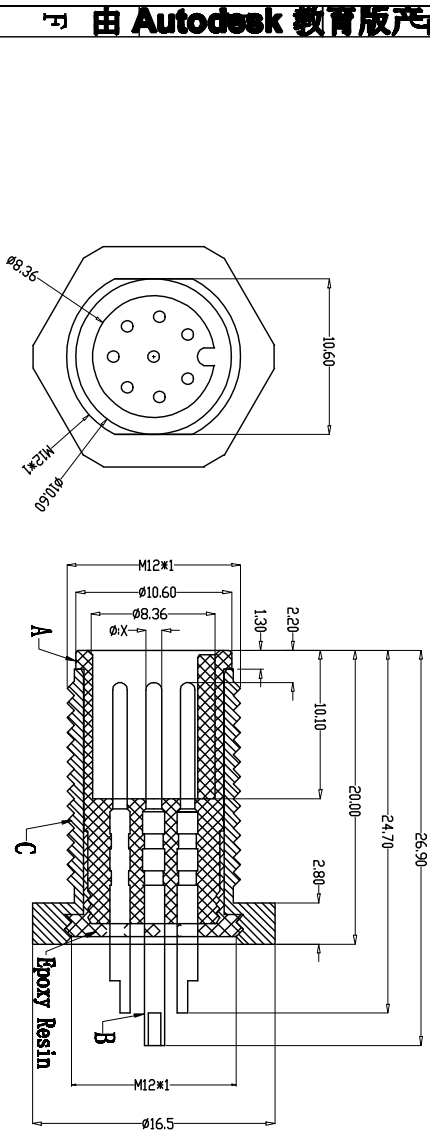
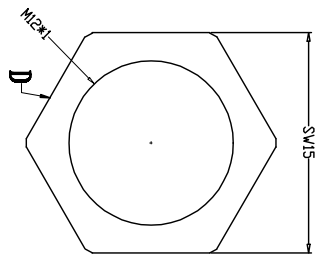
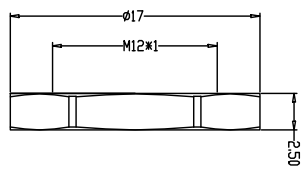
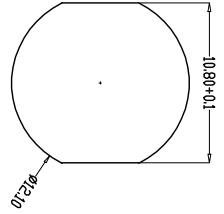

由 Autodesk 教育版产品制作

由 Autodesk 教育版产品制作

PARTS		MATERIALS		TREATMENT		AMOUNT
A	HOUSING	PA66+GF		GOLD PLATED		1
B	CONTACT	BRASS		NICKEL PLATED		2*8
C	OUTER CONTACT	BRASS		NICKEL PLATED		1
D	NUT	BRASS		NICKEL PLATED		1
E	O-RING	EPDM		BLACK		1
F						

<p><b>Dongguan Changjun Electronics Co., LTD</b> <b>东莞市昌骏电子有限公司</b></p>		<p>TITLE: M12防水连接器公头 背面视图2 2015T</p>	
<p>TOLERANCE: ±0.05 ±0.10 ±0.20 ±0.50</p>		<p>DRAWING NO.: CP-M120136</p>	
<p>DATE: 1 / 1</p>		<p>UNIT: mm</p>	
<p>DRAWN: Xie Junjun</p>		<p>CHECK: Long Jibang</p>	
<p>DATE: 2022-01-05</p>		<p>REV: A/0</p>	